

mvBlueCOUGAR-X POE-I

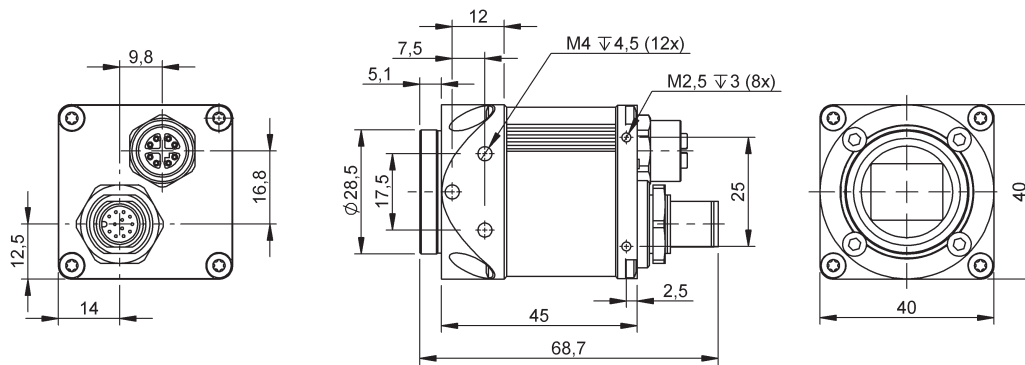

Dimensions in mm
 CS-mount is 5 mm shorter in length



Sensors

mvBlueCOUGAR-X	Resolution (H x V pixels)	Sensor size (optical)	Pixel size (µm)	Frame rate	Sensor-technology	Readout type	ADC resolution / output in bits	Sensor	
-100w	G/C	752 x 480	1/3"	6 x 6	117	CMOS	Global	10 → 12/10/8	Aptina MT9V
-100f	G/C	728 x 544	1/2.9"	6.9 x 6.9	299.8	CMOS	Global	12 → 16/12/8	Sony IMX287
-102e	G/C	1280 x 1024	1/1.8"	5.3 x 5.3	60	CMOS	Global	10 → 10/8	E2V EV76C560
-102f	G/C	1456 x 1088	1/2.9"	3.45 x 3.45	74.9	CMOS	Global	12 → 16/12/8	Sony IMX273
-102m	G/C	1608 x 1104	1.1"	9 x 9	67.2	CMOS	Global	12 → 16/12/8	Sony IMX425
-202m	G/C	1608 x 1104	1.1"	9 x 9	67.2	CMOS	Global	12 → 16/12/8	Sony IMX425
-102k	G/C	1608 x 1104	1.1"	9 x 9	67.2	CMOS	Global	12 → 16/12/8	Sony IMX432
-102n	G/C	1632 x 1248	1/1.7"	4.5 x 4.5	58.3	CMOS	Global	12 → 16/12/8	Sony IMX430
-104f	G/C	1936 x 1216	1/1.2"	5.86 x 5.86	46.9	CMOS	Global	12 → 16/12/8	Sony IMX249
-104i	G/C	2064 x 1544	1/1.8"	3.45 x 3.45	37.2	CMOS	Global	12 → 16/12/8	Sony IMX265
-105	G/C	2592 x 1944	1/2.5"	2.2 x 2.2	14	CMOS	Rolling	12 → 12/10/8	Aptina MT9P
-105p	G/C	2464 x 2056	2/3"	3.45 x 3.45	23.4	CMOS	Global	12 → 16/12/8	Sony IMX250_POL
-105b	G/C	2464 x 2056	2/3"	3.45 x 3.45	23.4	CMOS	Global	12 → 16/12/8	Sony IMX264
-105d	G/C	2472 x 2064	1/1.8"	2.74 x 2.74	23.2	CMOS	Global	12 → 16/12/8	Sony IMX547
-107b	G/C	3216 x 2208	1.1"	4.5 x 4.5	16.7	CMOS	Global	12 → 16/12/8	Sony IMX428
-108a	G/C	2856 x 2848	2/3"	2.74 x 2.74	14.5	CMOS	Global	12 → 16/12/8	Sony IMX546
-109b	G/C	4112 x 2176	1"	3.45 x 3.45	13.2	CMOS	Global	12 → 16/12/8	Sony IMX267
-1010	G/C	3856 x 2764	1/2.3"	1.67 x 1.67	7	CMOS	Rolling	12 → 12/10/8	Aptina MT9J
-1012b	G/C	4112 x 3008	1.1"	3.45 x 3.45	9.6	CMOS	Global	12 → 16/12/8	Sony IMX304
-1020	G/C	5544 x 3692	1"	2.4 x 2.4	5.8	CMOS	Rolling	12 → 16/12/8	Sony IMX183

Hardware Features

Protocol	Compliant to GigE Vision
Interface	Gigabit Ethernet (1000 Mbit/s with 100 Mbit/s compatibility)
Image formats	Mono8, Mono12, Mono14, Mono16, Mono12Packed Depends on camera type: BayerGR8, BayerGR10, BayerGR12, BayerGR16, BayerGR12Packed (or RG, GB, BG) RGB8Packed, BGR8Packed, BGRA8Packed, BGR10V2Packed, YUV422Packed, YUV422_YUYVPacked, YUV444Packed
Triggers	External, software based or free run
Size of body (W x H x L)	39.8 x 39.8 x 35 mm
Weight w/o lens	approx. 127 g
Permissible ambient temperature	Operation: 0...45 °C / 30 to 80 % RH Storage: -20 .. 60 °C / 20 to 90 % RH
Lens mounts	Back focus adjustable C/CS-mount lens holder, C-/CS-mount with factory set back focus, S-mount
Digital I/Os	4 opto-isolated inputs / 4 opto-isolated outputs
Image memory	64 MB, -202m: 128 MP
Conformity	CE, FCC, RoHS
Driver	mvIMPACT Acquire SDK or any GigE Vision compliant interface
Special features	Enhanced color and I/O functionality, automatic gain / exposure control, binning, burst mode, pre-trigger recording, internal temperature sensors